

Bicapped Tetrahedral, Trigonal Prismatic, and Octahedral Alternatives in Main and Transition Group Six-Coordination

Roald Hoffmann,*^{1a} James M. Howell,^{1b} and Angelo R. Rossi^{1c}

Contribution from the Departments of Chemistry, Cornell University, Ithaca, New York 14853, Brooklyn College, City University of New York, Brooklyn, New York, 11210, and The University of Connecticut, Storrs, Connecticut 06268. Received June 30, 1975

Abstract: We examine theoretically the bicapped tetrahedron and trigonal prism as alternatives to the common octahedron for six-coordinate main and transition group compounds. The pronounced preference of six-coordinate sulfur for an octahedral geometry is traced by a molecular orbital analysis to a pair of nonbonding levels, whose higher energy in the nonoctahedral geometries is due to the molecular orbital equivalent of a ligand–ligand repulsion. For transition element complexes we draw a correlation diagram for the trigonal twist interrelating octahedral and trigonal prismatic extremes. A possible preference for the trigonal prism in systems with few d electrons is discussed, as well as a strategy for lowering the energy of the trigonal prism by symmetry-conditioned π bonding. The bicapped tetrahedron geometry for transition metal complexes can be stabilized by a substitution pattern ML_4D_2 where D is a good σ donor and M is a d^6 metal center.

In main and transition group six-coordinate compounds the octahedral geometry predominates. There is, however, a growing class of trigonal prismatic complexes and structures intermediate between the octahedron and trigonal prism in coordination geometry.^{2a} In six-coordinate tin and other group 4 element chemistry a wide range of coordination geometries has been found.^{2b} Some six-coordinate transition metal dihydrides, of the general formula H_2ML_4 , are highly distorted toward a bicapped tetrahedron.³ Presently there exists a unique non-hydride, $Fe(CO)_4(Si(CH_3)_3)_2$, which exhibits a similar distortion.⁴ We also have the fascinating structural problem of xenon hexafluoride.⁵ All these compounds, highly interesting in their own right, so far add up to but a small percentage of the myriad of complexes which assume a geometry close to octahedral.

Octahedral or near-octahedral six-coordinate molecules are generally stereochemically rigid. Perhaps this is more often assumed than proven, but we have the most direct demonstration in the isolation, under ambient conditions, of many cis–trans isomeric pairs of ML_4XY complexes. In some molecules we also possess an NMR demonstration of the relative rigidity of ML_5X species. A case in point is $C_6H_5SF_5$, where the ^{19}F spectrum shows an AB_4 pattern up to 215 °C.⁶ Further stereochemical proofs or rigidity come from the optical activity of tris–chelate complexes $M(L \cdots L')_3$. Studies of the kinetics of isomerization and racemization of such complexes have provided careful and indeed elegant mechanistic contributions to the chemical literature.⁷ In most cases the obvious twist mechanism^{8,9} could be eliminated, with bond rupture to a five-coordinate intermediate favored instead.^{10,11} More recently there have appeared several studies strongly supporting the operation of a twist mechanism or its permutational equivalent.¹²

The term “permutational equivalent” signals a heightened sensitivity, in recent times, to what the experiments are indeed telling us. A fully analyzed NMR spectrum gives us information on which sites are dynamically equivalent to others at a given temperature. The full set of $N!$ permutations of the N ligands of an ML_N complex factors into a much smaller number of distinct basic permutational sets^{13,14} or the somewhat differently defined rearrangement modes.^{14–17} An optimal NMR experiment, including an analysis of line shapes, may distinguish between some or all of the basic permutational sets.

There is some neat mathematics in the graphical, topo-

logical, or group theoretical analysis of rearrangement modes or basic permutational sets. However, the solution of the mathematical problem leaves the question of the physical mechanism of a rearrangement still unsolved. A given permutation may be accomplished by a number of physically distinct atomic motions. The permutational formalism is useful in suggesting what geometrical way-points might be examined in detail on the potential surface for the rearrangement.

The purpose of this paper is not to examine the full surface for an ML_6 complex. If the M–L distance is kept constant, that surface is nine-dimensional, and its complete survey certainly within the reach of modern semiempirical methods. However, we choose to begin with the known great preference for the octahedral geometry and to answer the question why SF_6 or $Cr(CO)_6$ prefer to be octahedral. As alternative structures to the octahedron **1**, we will consider the trigonal prism **2**, and the bicapped tetrahedron **3**. An understanding of the electronic structure of **1**, **2**, and **3** will provide us with the strategy for shifting, if possible, the conformational balance from **1**.

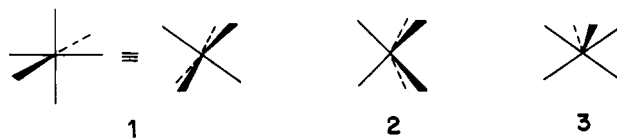

Previous Discussions of ML_6 Geometries

An interesting early discussion of why octahedral coordination is preferred to trigonal prismatic was given by Hultgren.¹⁸ Within the valence bond framework of constructing at the metal hybrids which maximize overlap with ligand orbitals, he concluded that a trigonal prism configuration would have greater energy per bond, but the octahedron would have smaller repulsive forces between the surrounding atoms.

Thus in the above discussion ligand–ligand repulsion was already introduced. In Gillespie’s scheme of the determinants of molecular geometry^{19a} the emphasis is on the repulsion of bond electron pairs (and lone pairs where necessary). For SF_6 and d^0 and d^{10} systems the problem of the best arrangement of six localized electron pairs is isomorphic to the ligand–ligand repulsion problem. The explicit form of the interaction potential is left unspecified, but in the

specific case of six points this is immaterial, for the octahedron is preferred for all repulsive potentials. Note that the nonoctahedral geometry of XeF_6 is correctly predicted by the Gillespie model, by invoking a stereochemically active lone pair.^{19b} This molecule has been the subject of a number of theoretical studies, the geometrically most detailed of which is by Wang and Lohr.²⁰

For transition metal complexes the question of departures from octahedral geometry has received considerable attention, within the framework of crystal and ligand field theory and the application of first- and second-order Jahn-Teller arguments.^{21,22}

Fay and Piper, in their pioneering study of the racemization and isomerization of tris-chelate complexes, calculated crystal field stabilization energies for $d^6 O_h$ and D_{3h} geometries.⁹ They reported that surprisingly the stabilization energy was greater for the trigonal prismatic coordination. This in turn implied that the observed preference for octahedral coordination was set by the ligand-ligand repulsions, which, as we mentioned above, greatly favor the octahedron. More recent ligand-field and angular overlap model studies have given us a good picture of the way that the energy levels vary along a trigonal twist reaction coordinate.²³⁻²⁷ The relationship of the bicapped tetrahedron has been investigated in but one of these studies, that of Burdett.²⁷

SR₆ and Six-Coordinate d⁰ and d¹⁰ Systems

We have found it useful to separate the analysis of six-coordinate main group compounds, such as SF_6 , SiF_6^{2-} , PF_6^- , and their derivatives, from six-coordinate transition metal complexes. Model calculations of ab initio and extended Hückel (EH) types were carried out on SH_6 in octahedral and trigonal prismatic geometries. Details are given in the Appendix. An SCF optimization of the SH distance in octahedral SH_6 yielded a value of 1.40 Å,²⁸ which was consistently used throughout our calculations.

There are two trigonal prism geometries that we considered, one obtained by a simple rotation of one triangular face of an octahedron by 60°, the other an optimized geometry subject to a D_{3h} constraint and the constant SH distance mentioned above. If we define the metal to ligand distance as l , the ligand-ligand distance within one triangle as s , and the distance between the triangular planes as h ³¹ (see 4), then in the simply twisted trigonal prism $h = \sqrt{4/3} l =$

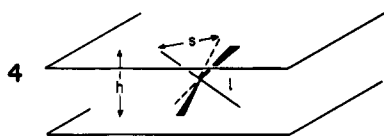

1.617 Å and $s = \sqrt{2} l = 1.900$ Å. In the optimum energy prism $h = 1.856$ Å and $s = 1.816$ Å. Unless otherwise stated, a reference to a trigonal prismatic SH_6 will refer to this optimum geometry.

The octahedral geometry was preferred to the trigonal prism by 4.2 eV in the SCF calculation with d orbitals absent from the basis set, 4.4 eV in an SCF calculation with 3d orbitals included, 2.9 eV for EH without 3d orbitals, and 1.8 eV for EH with 3d orbitals low-lying and contracted for optimum interaction. The wave functions for both O_h and D_{3h} geometries are much the same in the SCF and EH calculations.

The problem of d orbital participation in "octet expanded" silicon, phosphorus, and sulfur structures is an old one.³² Our pragmatic view is that since it is difficult to delineate the extent of participation of 3d orbitals, and unproductive to argue about it, it is best to consider the extremes

of no participation and strong mixing. We intend to try to understand any phenomenon in the absence of d orbital participation, then to examine how d orbital mixing changes the situation.

In both the EH and SCF calculations SH_6 has a substantial preference for the octahedral geometry even in the absence of 3d orbitals in the sulfur basis set. Let us first trace that effect. Figure 1 shows a standard interaction diagram for O_h and D_{3h} geometries of SH_6 .

The important point to note is that in the absence of 3d orbital mixing there is a nonbonding pair of orbitals which, in either O_h or D_{3h} symmetry, is entirely localized on the ligands. This is the e_g set in O_h , e'' in D_{3h} . Just counting metal-ligand interaction we would not find any difference between the two geometries—each would have four strongly bonding levels and two nonbonding ones. When the calculations are actually examined, they show that the e_g and e'' levels are not at the same energy. For instance in the EH calculation without 3d e_g is at -11.24 eV, e'' at -10.47 eV. The barrier to the trigonal twist interconverting the O_h and D_{3h} geometries is predominantly due to these e levels.

Why is there such a large difference in energy between the e_g and e'' levels? That energy differential is the result of ligand-ligand interaction and the geometrical constraints of the trigonal prismatic coordination. The octahedral e_g levels are entirely determined by symmetry. They are shown in 5 and 6. In 7 and 8 the same orbitals are shown in a different

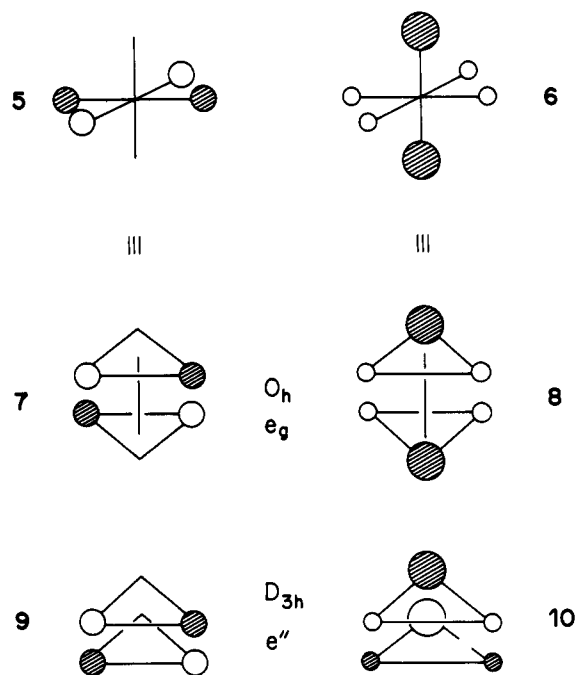

view, one that has the vertical axis coincide with a threefold rotation axis of the octahedron. This coordinate system is natural for intercomparing the octahedron and the trigonal prism, for the motion relating them leaves the threefold axis intact. The e'' levels of the trigonal prism are shown in 9 and 10. It is obvious that the e_g and e'' levels have really the same shape—they both are composed from the out-of-phase combination of symmetry-adapted three levels of each triple of hydrogens. The e'' and e_g levels are antibonding within each triple of hydrogens and antibonding across to the other triple. The effect is a net one—that is there are bonding contributions, visible especially in 8 and 10, but they are outweighed by the antibonding overlaps. Since the two e'' or e_g components are equivalent, let us concentrate on 7 and 9.

The e'' component 9 is at considerably higher energy than the e_g level which is its counterpart, 7. The reasons for this are geometrical. Referring back to structure 4 and the

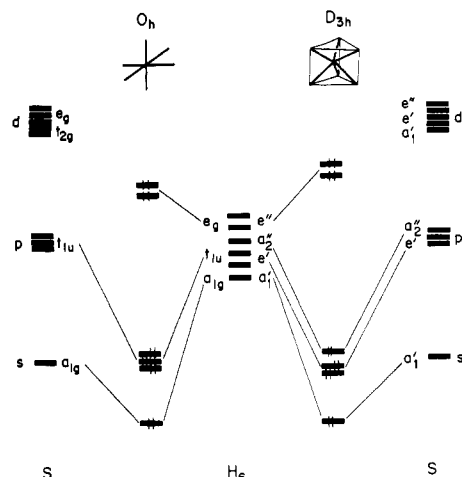

Figure 1. Interaction diagram for octahedral (left) and trigonal prismatic (right) SH_6 .

associated definitions of l , s , and h , consider first the simple rigid rotation of one triangle of an octahedron relative to the other by 60° . In the trigonal prism that results the interplane distance $h = \sqrt{4/3}l$ is maintained and in fact becomes the shortest ligand–ligand contact, shorter than the octahedral $s = \sqrt{2}l$. Since the corresponding ligand orbitals are required to be out-of-phase (see 7 and 9), there is more antibonding in the trigonal prism orbital.

One could try to escape this situation by not imposing the constraint that the h be constant during the trigonal twist. But for a constant l this can only be achieved by making s less than it is in the octahedron. In particular if we make $h = \sqrt{2}l$, then $s = \sqrt{3/2}l$, to be compared to $\sqrt{2}l$ in the octahedron. Since the e'' orbital is also net antibonding within a triangle, such a geometry will also be destabilized relative to the octahedron. To summarize: in any D_{3h} geometry the e'' orbital will be more antibonding, less stable than the corresponding e_g orbital of an octahedron with the same M–L distance.³³

It should be noted that at this stage the MO rationalization of the preferred octahedral geometry has come to the orbital equivalent of a ligand–ligand repulsion. This is not unexpected, but it is interesting to note those other cases where a connection between an orbital theory and an electrostatic or steric explanation can be made.³⁴ Another interesting connection to be made is between the present work and the origins of the barrier to internal rotation in ethane. In a one-electron MO analysis the ethane barrier is traced to the e levels of two interacting methyl groups.³⁵ These combine to an e_g and e_u set in the staggered conformation, e'' and e' in the eclipsed form. The greater ligand–ligand interaction, net repulsive, in the eclipsed geometry is the determining factor in both the ethane barrier and octahedral vs. trigonal prismatic SH_6 . The slight lengthening of CH bonds that is observed in calculations on eclipsed ethane conformations is matched by an analogous effect in our SH_6 calculations. If the bond lengths in the trigonal prism are independently optimized, they come out 0.05 \AA longer than the octahedral value with a basis set that excludes 3d orbitals, 0.02 \AA longer if 3d orbitals are included.

We turn briefly to an analysis of an alternate ML_6 structure, the bicapped tetrahedron 3. The idealized geometry places the six hydrogens at the corners of a cube. An interaction diagram is shown in Figure 2. Once again we find four bonding levels and two nonbonding ones, when 3d orbitals are omitted. This recurrent pattern should be no surprise, for it is related to the united atom limit of this molecule or, alternatively, to a particle in a spherical box. Either

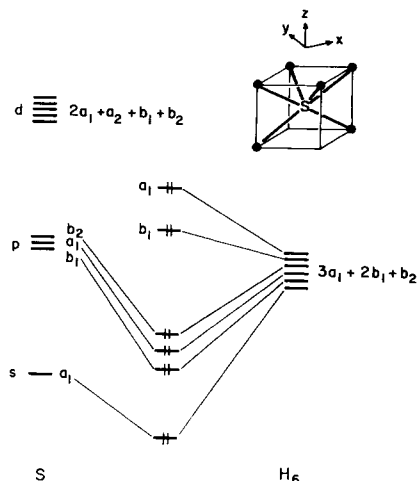
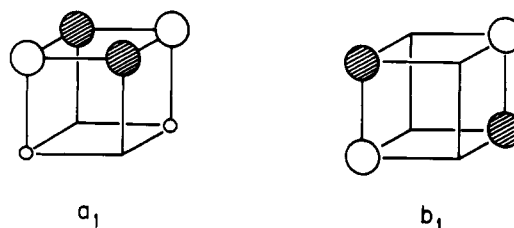

Figure 2. Interaction diagram for a bicapped tetrahedron geometry of SH_6 .

way we would expect a low-lying nodeless orbital, followed by three orbitals with one angular node. Only in O_h are these three orbitals degenerate. The breaking of the symmetry by departures from O_h does not change the essential pattern, which is set by the spherical pseudosymmetry of the problem.

The nonbonding orbitals of the bicapped tetrahedron have the following shape:



In a bicapped tetrahedron it need not be that all ML distances are equal. For instance it could be that the two capping atoms are further away from the central atom. In the absence of any relevant structural information, if we assume that all ML distances are equal, and the same as in the octahedron, the antibonding character of the a_1 and b_1 orbitals shown above is considerably greater than in the octahedron. In an extended Hückel calculation the a_1 level is at -8.84 eV , b_1 at -10.54 eV . The bicapped tetrahedron calculated by EH is 6.1 eV above the octahedron without 3d orbitals, 3.4 eV with 3d's. The destabilization is easily traced to the short contacts of $\sqrt{4/3}l$.

We proceed to an analysis of how 3d orbital participation affects the relative energies of the O_h and D_{3h} forms. Figure 1 is to be referred to at this point. The 3d levels transform as the irreducible representations e_g and t_{2g} in O_h . One of these, e_g , matches the symmetry of the crucial ligand orbital. In D_{3h} the 3d orbital set also has a counterpart to the ligand orbital e'' . Counting interactions alone, there would seem to be no additional differentiation between the two geometrical extremes. But this is not quite true. In the octahedron there is a perfect match between the 3d e_g set, z^2 and $x^2 - y^2$, and the symmetry-adapted ligand set. This is shown in 11 and 12.³⁶ In the trigonal prism the overlap of the e'' ligand orbitals with xz and yz , 13 and 14, is somewhat smaller. 13 shows especially well how this overlap is partially δ in character. Thus judging by overlap alone one would expect the difference in energy between O_h and D_{3h} to increase, since there is more efficient overlap with 3d functions and therefore stabilization of the occupied orbitals in the octahedral geometry. This is not reflect-

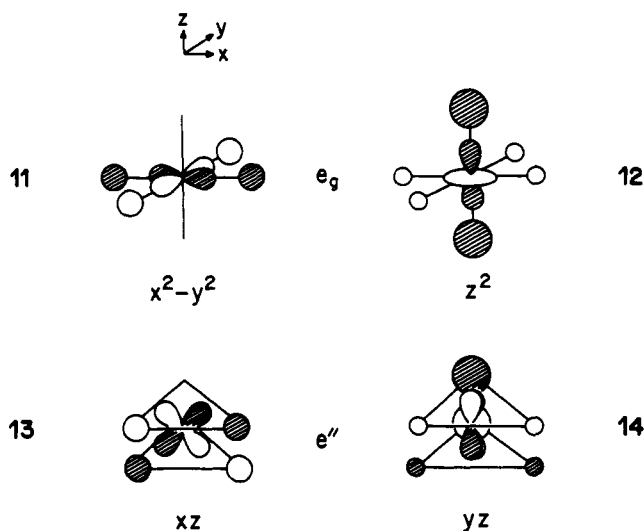

ed in the extended Hückel calculations. The reason for the discrepancy is that we cannot consider the overlap alone, but must worry about the energy denominator in the standard perturbation expression for the interaction energy

$$\Delta E = \frac{|H_{ij}|^2}{E_i - E_j}$$

Just because the nonbonding e'' levels are significantly higher than the e_g the former will interact better with a low-lying set of 3d orbitals. With the particular choice of 3d parameters used in our calculations the energy factor dominates. A similar effect takes place in the bicapped tetrahedron. The energy lowerings calculated for the trigonal prism and bicapped tetrahedron when 3d orbitals are included are to be viewed as extrema of 3d interaction, with realistic molecular systems somewhere in between.

In summary the preference for the octahedral geometry of SR_6 compounds is traced to nonbonding levels, destabilized by ligand-ligand overlap, and more so in the trigonal prism.

Six-Coordinate Transition Metal Complexes

Extended Hückel calculations on the prototype $Cr(CO)_6$ gave the octahedron an energy 1.3 eV lower than that for an idealized trigonal prism. To separate the effects of σ and π bonding we also performed a calculation on a model CrH_6^{6-} . The parameters for both calculations are described in the Appendix. The model hydride favored the octahedron by 2.9 eV.

The level pattern in both models is qualitatively that shown below. We illustrate only the levels which are derived

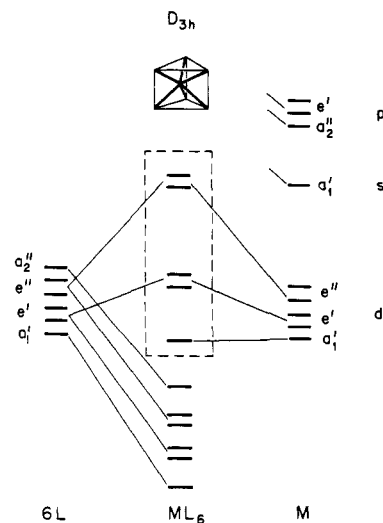
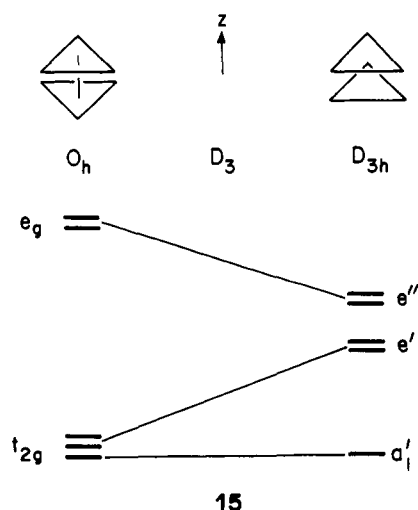

Figure 3. Interaction diagram for a trigonal prismatic transition metal complex.

from the metal 3d orbitals, even though the extent of mixing with ligand orbitals is often so great that such an identification is difficult to make. In the carbonyl case several carbonyl π^* levels moreover come below the e_g - e'' set indicated here.

The octahedral splitting of t_{2g} below e_g is most familiar. In the absence of π bonding ligands the t_{2g} set is pure metal 3d. If we imagine the trigonal twist proceeding, the triple degeneracy is split, with one level, the a_1' , z^2 , little affected by the motion. In the absence of π bonding ligands, as in the model chromium hydride, the trigonal twist indeed leaves the t_{2g} component which becomes a_1' in D_{3h} totally unaffected. This is because the twisting hydrogens are in the nodal surface of the z^2 orbital. With carbonyl substituents the a_1' component of t_{2g} moves to slightly lower energy in D_3 and D_{3h} , but the effect is small. The other t_{2g} component, e in D_3 , becoming e' in D_{3h} , is destabilized relative to the octahedron. It is composed on the metal of xy and $x^2 - y^2$, with some admixture of x and y . The easiest way to see the source of the destabilization of e' is to set up the interaction diagram for the trigonal prism, which is done in Figure 3. The important point is that the set of ligand orbitals contains an e' representative. This is the in-phase combination of the symmetry-adapted triangle e functions, analogous to the out-of-phase combination shown in 9 and 10. The overlap of these e' orbitals with metal xy and $x^2 - y^2$ is not good, but is sufficient to cause some destabilization.

There is nothing novel in our analysis of the level trends shown in 15. The ordering of D_{3h} levels is the same as that obtained previously by other workers.³⁷ The way that the levels vary with the trigonal twist has been analyzed by Tomlinson,²³ Wentworth,²⁴ Huisman et al.,²⁵ and Larsen et al.,²⁶ and our results agree with these investigators.

Level scheme 15 implies that the preference for the octahedron will be maximal for the low spin d^6 case. At either extreme of the transition series the trigonal prismatic geometry is of approximately equal energy to the octahedron. In fact our extended Hückel calculation for $Cr(CO)_6$, if used for an arbitrary number of electrons, gives a lower energy for D_{3h} over O_h for d^0 - d^4 and d^{10} . No doubt this is an artifact of using metal parameters outside the range of their validity, nevertheless we must face an apparent paradox. While the SL_6 system very clearly favored octahedral coordination, the extremes of the transition metal series, d^0 and d^{10} systems, which should give a similar result, do not appear to do so. The reason for this behavior may be found in a comparison of Figure 1 and Figure 3. As long as the d or-

bitals were high in energy (SH₆, Figure 1), and the bonding was set by s and p orbitals, both the octahedron and the trigonal prism had four bonding levels and two nonbonding, or more correctly said, slightly antibonding levels. The balance in favor of the octahedron was set by those nonbonding levels. The situation of Figure 3, where d orbitals are low, and s and p relatively high, is quite different. In the high symmetry of the octahedron only the e_g d orbital component can participate in σ bonding. In the trigonal prism the symmetry allows all d orbitals to participate in σ bonding. Because of their pseudosymmetry, they do not do so very effectively, but nevertheless there is a better σ bonding situation in the trigonal prism geometry when the metal 3d orbitals are at low energy.

It is clear that the geometry of a particular complex is not only governed by the d orbital patterns. The various structural parameters of the coordination sphere—the size of the metal ion, the bite angle of the ligands, their mutual steric interference—all these factors obviously will influence the observed equilibrium geometries. One cannot hope from model calculations to extrapolate directly to sterically encumbered bidentate ligands, but all we can do here is to trace as completely as possible the electronic effects predicted by our one-electron model. The next paragraphs review some of the experimental evidence pertinent to our conclusions: (1) low numbers of d electrons, especially d⁰–d², are the optimum situation for trigonal prismatic coordination; (2) for a given d electron configuration the lower the energy of the metal d orbitals, the stronger the metal–ligand bonding in the trigonal prism; (3) occupation of the e' levels will add an energy increment favoring the octahedron, while electrons in e'' restore the balance toward a trigonal prism.

The first trigonal prismatic complex proven as such was Re(S₂C₂Ph₂)₃.^{38a} It was followed by a number of similar complexes with sulfur or selenium chelating ligands.^{2a} The dithiolate ligand in its classical formulation is a dinegative ion. From this point of view these are d¹ Re(VI) complexes. The actual charge distribution in these complexes is far from that, as was recognized by Eisenberg and Gray in their molecular orbital calculations on a model for the trigonal prismatic structures.^{37a} Any configurational assignment depends on identifying highly delocalized orbitals as “belonging” to either ligands or metal, and is bound to be artificial. Nevertheless, to view these complexes as d¹ has some heuristic value, for it makes a consistent picture with the implications of level diagram 15. It might be noted that V(S₂C₂(CN)₂)₃²⁻, which might be counted as a d¹ complex, and Mo(S₂C₂(CN)₂)₃²⁻ and W(S₂C₂(CN)₂)₃²⁻, both d², possess solid-state structures intermediate between the trigonal prism and octahedron.^{38b}

The role of the energy of the 3d orbitals has been noted by Bennett, Cowie, Martin, and Takats,^{38c} who determined the structures of the isoelectronic tris(benzenedithiolato) complexes Mo(S₂C₆H₄)₃, Nb(S₂C₆H₄)₃⁻, and Zr(S₂C₆H₄)₃²⁻. The Mo complex is trigonal prismatic, the niobium analogue close to that geometry, while the Zr complex is closer to octahedral. The M–S distances increase along the series. Several other factors might be responsible for the trend, and were considered by the authors, but one determinant could be an increase in the d orbital energy as one moves from Mo to Zr.

That it is not unrealistic to imagine that a trigonal prismatic coordination geometry may have an advantage over an octahedral one for transition metal centers with few d electrons (d⁰–d²) becomes clearer if one leaves the domain of discrete molecules and considers extended solid-state structures. There is a large class of layered structures, disulfides and diselenides of Nb, Ta, Mo, and W, in which the

metal atoms lie in trigonal prismatic environments.^{37c} Similar coordination is found for metal atoms intercalated in the above structures. In some cases a temperature dependent equilibrium between trigonal prismatic and octahedral coordination is found, with the latter of higher energy.³⁹ The reader is referred to the interesting and comprehensive account of bonding in these structures by Huisman, De Jonge, Haas, and Jellinek.²⁵

A number of tris complexes with geometries intermediate between trigonal prism (twist angle between the two triangles of 0°) and octahedron (twist angle 60°) are known.^{2a,31} An interesting case in point is a comparison of two iron(III) complexes.⁴⁰ One, tris(*O*-ethylxanthato)iron is a low spin complex, with a configuration in the octahedral limit presumably corresponding to t_{2g}⁵. The other, tris(*N,N*-di-*n*-butylthiocarbamato)iron, is a high spin complex corresponding to the limiting configuration t_{2g}³e_g². The high spin complex has a structure with a twist angle of 32°, the low spin complex 41°. Both are intermediate in geometry, but it is consistent with our results that the low spin complex is closer to the octahedral limit. Other examples are discussed by Wentworth²⁴ and Larsen et al.²⁶

In the several mechanistic studies which have supported a twist mechanism, a correlation was sought between ease of rearrangement and a ground state distortion from octahedral toward trigonal prismatic coordination.⁴¹ Sometimes a case for such a correlation could be made, but there is one clear instance, that of the Co(III) complexes, where the correlation breaks down. These rearrange easily and yet are close to the octahedron (twist angle in one structure of 55°) in their ground state geometry. Another interesting question raised by the mechanistic studies is that of the effect of the chelating ligands. Acetylacetonates rearrange much slower (and apparently by a bond rupture mechanism) than tropolonates.⁴² It is not at all certain that π bonding effects contribute to the two observations quoted above. But it may be useful to analyze the role of π acceptors in favoring one or the other conformation within our bonding scheme.

The 12 orbitals of six cylindrically symmetrical π acceptor ligands transform as t_{1g} + t_{2g} + t_{1u} + t_{2u} in O_h, a₁' + a₂' + a₁'' + a₂'' + 2e' + 2e'' in D_{3h}. For hypothetical six-coordinate d⁷–d¹⁰ structures such an acceptor set could produce a stabilization of the trigonal prismatic geometry. This is because the metal e_g has no acceptor orbitals to interact with in the octahedron, but metal e'' in the trigonal prism finds a match in the acceptor set.

Now let us consider a set of three chelate ligands, as shown in 16 below. Each ligand will have a π -system, and in particular let us assume it has a low-lying acceptor orbital. The π system can be thought of as a ribbon, and the acceptor orbital can be p type or d type, respectively symmetric, 17, or antisymmetric, 18, with respect to a (pseudo) mirror plane bisecting the ribbon.⁴³ If the individual ribbon accep-

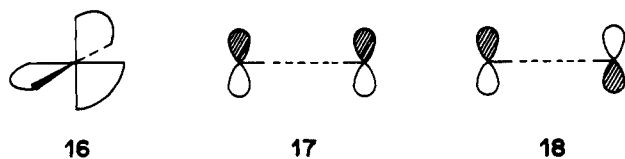

tor orbital is locally symmetric, the three ribbon acceptor orbitals will transform as a₂ + e in D₃, a₂' + e' in D_{3h}. If the ribbon is antisymmetric, we will have a₁ + e in D₃, a₁'' + e'' in D_{3h}.⁴⁴ In a d⁶ system, if we wish to stabilize the trigonal prism, we must lower the energy of the e' orbital. Only a symmetric ribbon can accomplish this.

In an acetylacetonate ligand, 19, we have a 6 π electron system extending over five atoms. The lowest unfilled π or-

bital is antisymmetric, of type **18**, and thus ineffective at stabilizing the trigonal prism. In a tropolonate ligand, **20**,



an extended Hückel calculation yields a pair of acceptor orbitals, one symmetric, one antisymmetric, with the symmetric one slightly lower. We were led to examine the lower lying unfilled π^* molecular orbitals of a series of real or potential bidentate ligands, **21–32**. In these structures X = O, S, or NH and Y = N.⁴⁵ For ligand systems **25**, **29**, and **32** the lowest unfilled orbital is antisymmetric, implying no tendency to stabilize a trigonal prismatic geometry. The other ligands have a symmetric or pseudo-symmetric LUMO, which according to this analysis should help in stabilizing a trigonal prism. In **22**, **23**, and **24** the symmetric

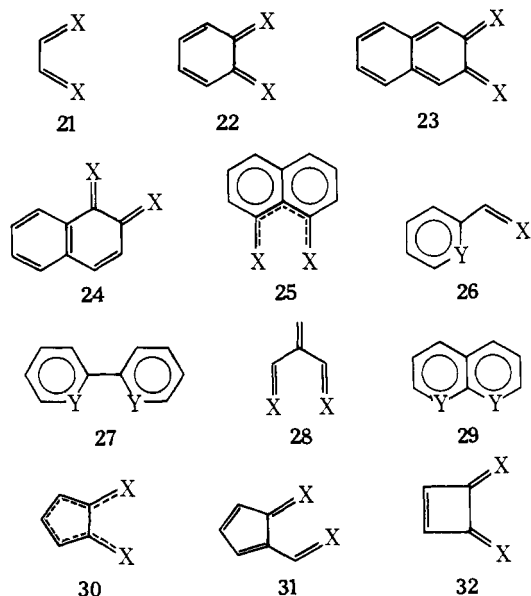

π^* orbital is especially low in energy and with large density at the interacting X site. Yet these circumstances favorable for π -bonding are not sufficient to ensure a distortion toward a trigonal prism. *o*-Benzoquinone complexes are known and unlike their sulfur analogues retain a preference for octahedral coordination.⁴⁶

Because each potential bidentate ligand comes with a specific bite size, it is unlikely that a comparison of different ligands will provide unambiguous evidence for a π effect. Perhaps another informative approach would be to keep the ligand intact but to vary the position of its acceptor orbital by substitution in sterically innocent sites. For instance the symmetrical tropolonate acceptor orbital has the coefficients shown in **33**. Sites 2, 4, and 6 carry large coeffi-

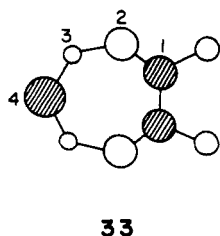

icients. The effect of substitution at site 4 would be interesting in that it should be electronically effective but likely to perturb little the steric environment of the metal atom.

π -Donor substituents at C₄ would raise the energy of this orbital, acceptors would lower it.

It should be noted that the angular overlap calculations of Larsen, LaMar, Wagner, Parks, and Holm²⁶ probed the significance of π -(anti)bonding. Their analysis, by taking the same sign for each ligand π energy term, essentially assumes a symmetric ribbon of type **18**. Within that assumption the effect of π -bonding on the energy of the e' level appears to be small—approximately as much stabilization of the e' occurs in the D_{3h} as the O_h geometry. These results would indicate that π bonding effects are of little importance in the energetics of the twisting process.

The Bicapped Tetrahedron Geometry for Transition Metal Complexes

We consider this geometry for two reasons: (1) the structural deformations observed in six-coordinate dihydrides of the type $H_2ML_4^3$ and in an unusual iron complex, $Fe(CO)_4(Si(CH_3)_3)_2$,⁴ are in the direction from an octahedron to a bicapped tetrahedron; (2) one of the five rearrangement modes of an octahedron is the permutation of two cis ligands.^{13–17} If one tries to construct a physical model for the transition state of such a cis interchange, one is led to a geometry close to a bicapped tetrahedron.

The latter point is illustrated below. The simplest way to

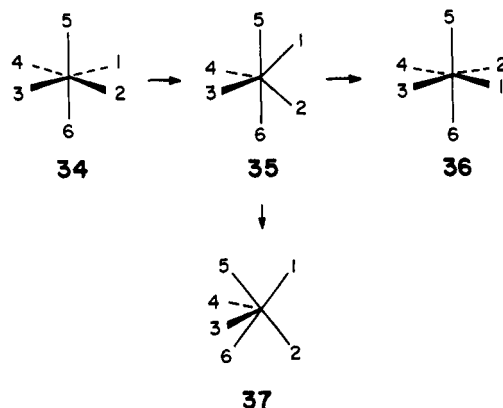

visualize the cis interchange of ligand 1 and 2 in **34** is to twist them around the bisector of the 1–M–2 angle. At 90° of twist, the midpoint **35** of this motion is attained, and at 180° the cis interchange is complete, **36**.²⁷ The midpoint **35** is a bicapped tetrahedron of sorts, but not the idealized structure illustrated in **3**. A further (or concomitant) distortion, in which the 5–M–6 angle is decreased from 180° to the tetrahedral angle τ , while the 3–M–4 and 1–M–2 angles simultaneously open from 90° to τ , reaches the idealized bicapped tetrahedron **37**. In this geometry the capping ligands 5 and 6 are located in the middle of two faces of the regular tetrahedron 1–2–3–4.

This is not the easiest way to get to the bicapped tetrahedron. The twisting motion suggested by the cis exchange is not needed if the goal is merely to move from an octahedron to a bicapped tetrahedron. If one just changes the 5–M–6, 3–M–4, and 1–M–2 angles from their respective initial values of 180°, 90°, and 90° all to τ , a motion which retains C_{2v} symmetry, the bicapped tetrahedron **38** is attained.

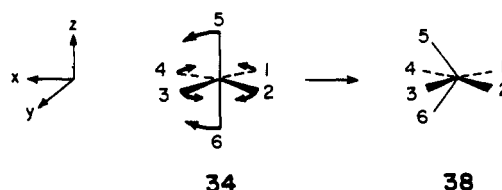

Let us construct a Walsh diagram for this distortion. It is convenient to use the somewhat unconventional coordinate

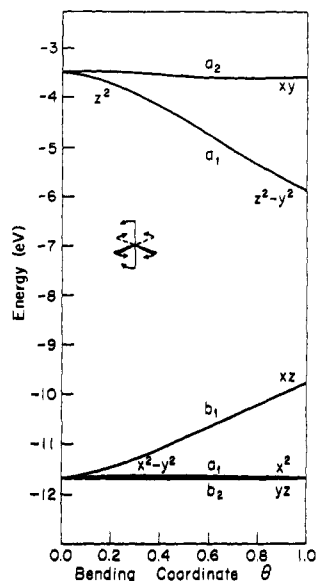
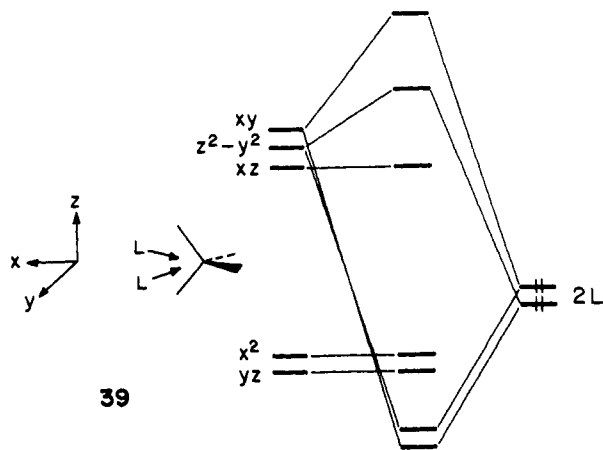

Figure 4. The behavior of the frontier orbitals of CrH_6^{6-} as a function of distortion from the octahedron to the bicapped tetrahedron. Progress of the reaction from **34** to **38** is measured by a bending coordinate, θ . At a given θ the 5-M-6 angle is given (in degrees) by $180 - (180 - \tau)\theta$ and the 1-M-2 and 3-M-4 angles are both $90 + (\tau - 90)\theta$. Thus $\theta = 0$ is the octahedron, and $\theta = 1$ is the idealized bicapped tetrahedron. τ is the tetrahedral angle. The two a_1 levels are labeled according to their character in the two extreme geometries.

system to the left of **34**, with x and y axes located between the ligands. In this coordinate system the octahedral t_{2g} set contains xz , yz , and $x^2 - y^2$, and the e_g orbitals are z^2 and xy . It is obvious that the motion illustrated in **34** will greatly stabilize the z^2 orbital by moving the axial ligands 5 and 6 off their sites of maximal σ antibonding. xy will similarly be stabilized slightly. In the t_{2g} set yz is unaffected, $x^2 - y^2$ somewhat destabilized, and xz strongly destabilized by σ antibonding with ligands 5 and 6. These qualitative conclusions are supported by the computed energy levels for a model CrH_6^{6-} system in which the ligands bear only σ type orbitals (Figure 4). Note that what were the z^2 and $x^2 - y^2$ orbitals in O_h mix strongly along the reaction coordinate, since they are both of a_1 symmetry in C_{2v} . In the bicapped tetrahedron the mixing is precisely such as to form an " x^2 " orbital, exactly nonbonding because the idealized geometry places all six ligands in its nodal surfaces. A similar distortion was studied for $\text{Cr}(\text{CO})_6$, with qualitatively similar results.

The orbital ordering of the bicapped tetrahedron is equally well derived by beginning with a tetrahedron and bringing in the two capping ligands. This is illustrated in **39**. Please note for further reference that, if the two incoming



ligands are normal bases, then **39** implies that the capping will be net destabilizing for a d^{10} system. This is because both the ligand orbitals and the metal functions they interact with are occupied.⁴⁷ If the ligand orbitals were empty, the interaction diagram would appear different. Placing the L orbitals above the tetrahedron t_2 set would produce a net stabilization of the d^{10} system through a lowering in energy of the xy and $z^2 - y^2$ orbitals. Structures such as HNiL_4^+ , $\text{HCo}(\text{CO})_4$, and $\text{H}_2\text{Fe}(\text{CO})_4$ can be viewed in this way, as protonated d^{10} ML_4 systems.

It is clear from Figure 4 that a d^6 system gives the octahedron the biggest advantage. For the model CrH_6^{6-} the octahedral geometry is preferred to the bicapped tetrahedron by 3.5 eV, for $\text{Cr}(\text{CO})_6$ by 2.7 eV. Both these energy increments are somewhat greater than those of trigonal prismatic coordination. Can the energy of the bicapped tetrahedron nevertheless be improved? Two strategies suggest themselves, one based on the differential charge distribution in the bicapped tetrahedron, the other on modifying the filling of the levels in Figure 4.

The charge distribution in the model CrH_6^{6-} is shown in **40**. A similar pattern is obtained for $\text{Cr}(\text{CO})_6$, with the cap-

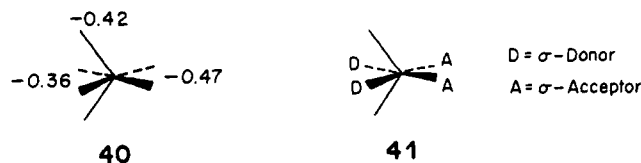

ping ligands 3 and 4 relatively positive and the sterically freer ligands 1 and 2 most negative. This suggests that more electronegative substituents (σ acceptors) would prefer the latter sites and more electropositive substituents (σ donors) would enter the former sites. The substituent pattern implied is that of **41**. Model calculations support the conclusion that such a pattern, or any piece thereof, would lower the energy of a bicapped tetrahedron.

The other approach for stabilizing a bicapped tetrahedron focuses on the Walsh diagram of Figure 4. Any electronic configuration which would deplete the population of the xz orbital and increase the population of $z^2 - y^2$ is going to favor distortion toward the bicapped tetrahedron. Such configurations are achieved in the lower excited states of an octahedron, and the bicapped tetrahedron has in fact been considered as a potential transition state for photochemical isomerization of six-coordinate complexes by Burdett.²⁷

Another way to achieve population of the $z^2 - y^2$ orbital is to make two of the six ligands such good donors that they effectively transfer their lone pair electrons to the metal, thereby changing it from a d^6 to a d^{10} configuration. The way in which this can happen is best explained by comparing the left side of Figure 5, an interaction diagram for a normal octahedral complex with all six ligands identical with the right side, where two trans ligands are made exceptionally good σ donors.

The two axial ligands L' form symmetry adapted symmetric and antisymmetric combinations which interact with metal z^2 (primarily, also with s) and z . The bonding combinations are shown in **42** and **43**. In the normal octahedron

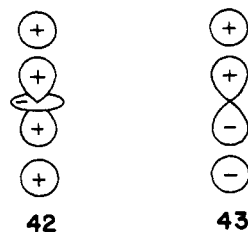

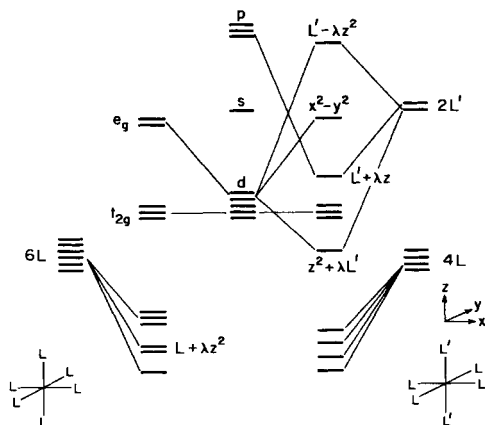

Figure 5. Interaction diagram for a normal octahedral complex (left) and for one in which two trans ligands, L' , are much better σ donors than the other four ligands. The mixing coefficient λ is to be assumed less than 1.

with all six ligands of identical σ -donor ability the bonding combinations are mainly localized on the ligands, and less so on the metal, i.e., $c_L > c_M$ in $\chi = c_L L + c_M d$. This is the situation at the left of Figure 5. Now suppose the two axial ligands, L' , become very good σ donors, rising in energy above the metal d orbitals. The coefficient ratio in the bonding combinations changes, now $c_M > c_L$. The two bonding combinations leave the octahedral grouping of six highly bonding low-lying levels and move up. The combination **43** moves up rapidly, since one of its components is anyway a high-lying metal p. The situation depicted at right in Figure 5 has that bonding combination between the "t_{2g}" set and $x^2 - y^2$. Making L' a still better donor might even cause a crossing of $x^2 - y^2$ and **43**, with a switchover of the electron pair to the metal. At the same time the bonding combination **42** is becoming increasingly localized on the metal, looking more and more like z^2 . In the extreme case we have changed a d^6 to a d^{10} complex.

An alternative way to see the change in electron configuration as a function of the σ -donor strength of the ligands is to think of the specific case of FeL_4H_2 . We normally think of the hydrogen as a hydride, H^- , and assign to the iron the formal oxidation state II, corresponding to d^6 . But at the other limit, were we to view the hydrogen as protonic, H^+ , we would have a d^{10} transition metal center. The truth is somewhere in-between those two extremes. In general, in the complex $\text{ML}_4\text{L}'_2$, we can achieve a range of d electron population on the metal by varying the relative σ donor strength of the ligands.

It is then possible to make a connection to an earlier discussion of $\text{ML}_n\text{L}'$ and $\text{ML}_n\text{L}'_2$ geometries.⁴⁸ If L' is a much better σ donor than L , then the equilibrium geometries of these molecules will be set by the geometrical preferences of the ML_n^{2-} and ML_n^{4-} fragments, respectively.

In concluding our initial discussion of the distortion to a bicapped tetrahedron, we must emphasize that our preoccupation with an electronic explanation for this deformation should not be interpreted as an argument for the unimportance of steric factors. These obviously matter. Our desire to point to the unusual $\text{Fe}(\text{CO})_4(\text{Si}(\text{CH}_3)_3)_2$ structure as an example of an electronically controlled deformation must also be tempered by the knowledge that compounds which are electronically not in an obvious way dissimilar, $\text{Fe}(\text{C}-\text{O})_4(\text{CF}_2\text{CHF}_2)_2$ ⁴⁹ and $\text{Ru}(\text{CO})_4(\text{GeCl}_3)_2$,⁵⁰ possess structures close to octahedral.⁵¹ A secondary reason for pointing to the bicapped tetrahedron is simply to get people used to thinking about still another six-coordinate geometry. Even in the class of tris-chelate structures, which might have

Table I. Extended Hückel Parameters

Orbital	H_{ii}	Exponents ^a	
		ζ_1	ζ_2
Cr 3d	-11.67	5.15 (0.51392)	1.70 (0.69290)
Fe 3d	-13.50	5.35 (0.53659)	1.80 (0.66779)
Cr 4s	-9.75	0.970	
Cr 4p	-5.89	0.970	
Fe 4s	-10.56	1.575	
Fe 4p	-6.19	0.975	
C 2s	-21.40	1.625	
C 2p	-11.40	1.625	
O 2s	-32.30	2.275	
O 2p	-14.80	2.275	
S 3s	-20.00	2.122	
S 3p	-11.00	1.827	
S 3d	-8.00	1.500	
H 1s	-13.60	1.300	

^a Two Slater exponents are listed for the 3d functions. Each is followed in parentheses by the coefficient in the double ζ expansion.

seemed ideally predisposed to occupy some point on the continuum connecting octahedral and trigonal prismatic geometries, there are a number of puzzling departures from D_3 symmetry.⁵²⁻⁵⁴ Perhaps one should examine how far these structures are from a bicapped tetrahedron.

Acknowledgment. We are grateful to W. A. G. Graham for communicating some structural information prior to publication, and to D. M. P. Mingos for playing an interesting role in this communication process. We also thank J. K. Burdett, M. Elia, R. C. Fay, R. H. Holm, and J. Takats for some discussions on this problem and C. C. Levin for some assistance in the calculations. The SH_6 octahedron vs. trigonal prism problem was posed for several years running on a Cornell graduate course final and was successfully solved by the great majority of students in the course. Our work was generously supported by the National Science Foundation and the Advanced Research Projects Agency through the Materials Science Center at Cornell University. J.M.H. acknowledges a grant of computer time from the Central Computer Facility of C.U.N.Y.

Appendix

The ab initio calculations on SH_6 without 3d orbitals were performed with the GAUSSIAN 70 program,⁵⁵ employing an STO-3G basis for both H and S atoms.⁵⁶ For SH_6 calculations with 3d orbitals we used IBMOL-5 with STO-3G type basis.⁵⁷

All other calculations on SH_6 and those on CrH_6^{6-} , $\text{Cr}(\text{CO})_6$, and $\text{Fe}(\text{CO})_4\text{H}_2$ were carried out by the extended Hückel method.⁵⁸ The parameters are summarized in Table I.

For CrH_6^{6-} a Cr-H distance of 1.60 Å was assumed. In $\text{Cr}(\text{CO})_6$ we took Cr-C, 1.80 Å, and C-O, 1.13 Å. In $\text{Fe}(\text{CO})_4\text{H}_2$ we used Fe-C, 1.83 Å, Fe-H, 1.58 Å, and C-O, 1.13 Å. The SH distances are discussed in the text. With 3d orbitals in the basis the SH distance optimized at 1.34 Å in the octahedron, 1.36 Å in the optimum trigonal prism.

References and Notes

- (1) (a) Cornell University; (b) Brooklyn College; (c) The University of Connecticut.
- (2) (a) Two reviews with leading references are R. Eisenberg, *Prog. Inorg. Chem.*, **12**, 295 (1970); R. A. D. Wentworth, *Coord. Chem. Rev.*, **9**, 171 (1972). (b) See for instance E. O. Schlemper, *Inorg. Chem.*, **8**, 2012 (1967); T. Kimura, N. Yasuoka, N. Kasai, and M. Kakudo, *Bull. Chem. Soc. Jpn.*, **45**, 1649 (1972); P. H. Bird, A. R. Fraser, and C. F. Lau, *Inorg. Chem.*, **12**, 1322 (1973). The structural chemistry of tin is reviewed by B. V. K. Ho and J. J. Zuckerman, *J. Organomet. Chem.*, **49**, 1 (1973).

- (3) See the review by B. A. Frenz and J. Ibers in "Transition Metal Hydrides", E. L. Muetterties, Ed., Marcel Dekker, New York, N.Y., 1971, p 33; L. J. Guggenberger, D. D. Titus, M. T. Flood, R. E. Marsh, A. A. Orto, and H. B. Gray, *J. Am. Chem. Soc.*, **94**, 1135 (1972). An electron diffraction study of $\text{H}_2\text{Fe}(\text{CO})_4$ may be found in E. A. McNeill, Ph.D. Dissertation, Cornell University, 1975.
- (4) M. J. Bennett, W. A. G. Graham, R. A. Smith, and L. Vancea (University of Alberta), private communication.
- (5) L. S. Bartell and R. M. Gavin, Jr., *J. Chem. Phys.*, **48**, 2466 (1966); H. H. Claassen, G. L. Goodman, and H. Kim, *ibid.*, **56**, 5042 (1972); U. Nielsen, R. Haensel, and W. H. E. Schwarz, *ibid.*, **61**, 3581 (1974).
- (6) F. N. Tebbe, P. Meakin, J. P. Jesson, and E. L. Muetterties, *J. Am. Chem. Soc.*, **92**, 1068 (1970).
- (7) The subject is reviewed by F. Basolo and R. G. Pearson, "Mechanisms of Inorganic Reactions", 2nd ed, Wiley, New York, N.Y., 1967, pp 300-334, and more recently by J. J. Fortman and R. E. Sievers, *Coord. Chem. Rev.*, **6**, 331 (1971), and N. Serpone and D. G. Bickley, *Prog. Inorg. Chem.*, **17**, 391 (1972).
- (8) (a) J. C. Bailar, Jr., *J. Inorg. Nucl. Chem.*, **8**, 165 (1958); (b) P. Rây and N. K. Dutt, *J. Indian Chem. Soc.*, **20**, 81 (1943); (c) C. S. Springer, Jr., and R. E. Sievers, *Inorg. Chem.*, **6**, 852 (1967); J. J. Fortman and R. E. Sievers, *ibid.*, **6**, 2022 (1967); (d) J. E. Brady, *ibid.*, **8**, 1209 (1969).
- (9) R. C. Fay and T. S. Piper, *Inorg. Chem.*, **3**, 348 (1964).
- (10) (a) J. G. Gordon, II, and R. H. Holm, *J. Am. Chem. Soc.*, **92**, 5319 (1970); (b) J. R. Hutchison, J. G. Gordon, II, and R. H. Holm, *Inorg. Chem.*, **10**, 1004 (1971).
- (11) (a) N. Serpone and R. C. Fay, *Inorg. Chem.*, **6**, 1835 (1967); (b) R. C. Fay, A. Y. Girgis, and U. Klabunde, *J. Am. Chem. Soc.*, **92**, 7056 (1970); (c) A. Y. Girgis and R. C. Fay, *ibid.*, **92**, 7061 (1970).
- (12) (a) L. H. Pignolet, R. A. Lewis, and R. H. Holm, *Inorg. Chem.*, **11**, 99 (1972); *J. Am. Chem. Soc.*, **93**, 360 (1971); (b) S. S. Eaton and R. H. Holm, *ibid.*, **93**, 4313 (1971); (c) S. S. Eaton, J. R. Hutchison, R. H. Holm, and E. L. Muetterties, *ibid.*, **94**, 6411 (1972).
- (13) J. P. Jesson and P. Meakin, *Acc. Chem. Res.*, **6**, 269 (1973). See also ref 6.
- (14) W. G. Klemperer, *J. Chem. Phys.*, **56**, 5478 (1972); *Inorg. Chem.*, **11**, 2668 (1972); *J. Am. Chem. Soc.*, **94**, 6940, 8360 (1972); **95**, 380, 2105 (1973).
- (15) J. I. Musher, *J. Am. Chem. Soc.*, **94**, 5662 (1972); *Inorg. Chem.*, **11**, 2335 (1972); J. I. Musher and W. C. Agosta, *J. Am. Chem. Soc.*, **96**, 1320 (1974).
- (16) M. Gielen and N. Van Laenen, *Bull. Soc. Chim. Belg.*, **79**, 679 (1970); M. Gielen and C. Depasse-Delit, *Theor. Chim. Acta*, **14**, 212 (1969); M. Gielen, G. Mayence, and J. Topart, *J. Organomet. Chem.*, **18**, 1 (1969); M. Gielen and J. Topart, *ibid.*, **18**, 7 (1969); J. Brocas, *Theor. Chim. Acta*, **21**, 79 (1971).
- (17) E. Ruch, W. Häslebarth, and B. Richter, *Theor. Chim. Acta*, **19**, 288 (1970); W. Häslebarth and E. Ruch, *ibid.*, **29**, 259 (1973).
- (18) R. Hultgren, *Phys. Rev.*, **40**, 891 (1932).
- (19) (a) R. J. Gillespie, "Molecular Geometry", Van Nostrand Reinhold, London, 1972; (b) R. J. Gillespie in "Noble-Gas Compounds", H. H. Hyman, Ed., The University of Chicago Press, Chicago, Ill., 1963, p 333.
- (20) S. Y. Wang and L. L. Lohr, Jr., *J. Chem. Phys.*, **60**, 3901 (1974). See also R. M. Gavin, Jr., *J. Chem. Educ.*, **46**, 413 (1969).
- (21) (a) See for instance I. B. Bersuker, *Zh. Strukt. Khim.*, **2**, 350, 734 (1961); (b) J. H. Van Vleck, *J. Chem. Phys.*, **7**, 72 (1939); M. D. Sturge, *Solid State Phys.*, **20**, 91 (1969); (c) L. E. Orgel, *Discuss. Faraday Soc.*, **26**, 138 (1958); *J. Chem. Soc.*, 4186 (1958); 3815 (1959).
- (22) R. G. Pearson, *J. Am. Chem. Soc.*, **91**, 4947 (1969).
- (23) A. A. G. Tomlinson, *J. Chem. Soc. A*, 1409 (1971).
- (24) (a) W. O. Gillum, R. A. D. Wentworth, and R. F. Childers, *Inorg. Chem.*, **9**, 1825 (1970); (b) R. A. D. Wentworth, *Coord. Chem. Rev.*, **9**, 171 (1972).
- (25) R. Huisman, R. De Jonge, C. Haas, and F. Jellinek, *J. Sol. State Chem.*, **3**, 56 (1971).
- (26) E. Larsen, G. N. LaMar, B. F. Wagner, J. E. Parks, and R. H. Holm, *Inorg. Chem.*, **11**, 2652 (1972).
- (27) J. K. Burdett, *Inorg. Chem.*, **15**, 212 (1976). For an observation of such an exchange process see W. Majunke, D. Leibfritz, T. Mack, and H. tom Dieck, *Chem. Ber.*, **108**, 3025 (1975).
- (28) In a calculation closer to the Hartree-Fock limit than ours, G. M. Schwenzler and H. F. Schaeffer, III, *J. Am. Chem. Soc.*, **97**, 1393 (1975), an optimum SH distance of 1.461 was computed. Other ab initio (ref 29) and semiempirical (ref 30) calculations on SF_6 or SH_6 are available.
- (29) (a) G. L. Bendazzoli, P. Palmieri, B. Cadioli, and U. Pincelli, *Mol. Phys.*, **19**, 865 (1970); (b) U. Gelius, B. Roos, and P. Siegbahn, *Chem. Phys. Lett.*, **4**, 471 (1970); (c) P. Gianturco, C. Guidotti, U. Lamanna, and R. Moccia, *Chem. Phys. Lett.*, **10**, 269 (1971).
- (30) (a) V. B. Koutecký and J. I. Musher, *Theor. Chim. Acta*, **33**, 227 (1974); (b) D. P. Santry and G. A. Segal, *J. Chem. Phys.*, **47**, 158 (1967); (c) K. A. R. Mitchell, *J. Chem. Soc. A*, 2676 (1968); (d) R. D. Brown and J. B. Peel, *Aust. J. Chem.*, **21**, 2605 (1968); (e) I. H. Hillier, *J. Chem. Soc. A*, 878 (1969).
- (31) The notation is chosen to match that of E. I. Stiefel and G. F. Brown, *Inorg. Chem.*, **11**, 434 (1972).
- (32) For a reasoned discussion see M. E. Dyatkina and N. M. Klimenko, *Zh. Strukt. Khim.*, **14**, 173 (1973), or C. A. Coulson, *Nature (London)*, **271**, 1106 (1969).
- (33) See the related discussion in ref 24b.
- (34) See also L. S. Bartell, *Inorg. Chem.*, **5**, 1635 (1966); *J. Chem. Educ.*, **45**, 754 (1968); R. M. Gavin, Jr., *ibid.*, **46**, 413 (1969).
- (35) J. P. Lowe, *J. Am. Chem. Soc.*, **92**, 3799 (1970); R. Hoffmann, *Pure Appl. Chem.*, **24**, 567 (1970). This one-electron argument has been criticized by I. R. Epstein and W. N. Lipscomb, *J. Am. Chem. Soc.*, **92**, 6094 (1970).
- (36) Note the coordinate system is a hybrid one, with z along the threefold axis in the trigonal prism, but along a bond in the octahedron. This is just a matter of convenience. If we kept the z axis along the threefold axis in the octahedron, the e_g orbitals would be the same, but would be given by a linear combination of the basis orbitals for that axis system.
- (37) (a) E. I. Stiefel, R. Eisenberg, R. C. Rosenberg, and H. B. Gray, *J. Am. Chem. Soc.*, **88**, 2956 (1966); (b) G. N. Schrauzer and V. P. Mayweg, *ibid.*, **88**, 3234 (1966); (c) F. Hulliger, *Struct. Bonding (Berlin)*, **4**, 83 (1968); (d) K. Anzenhofer, J. M. van den Berg, P. Cossee, and J. N. Helle, *J. Phys. Chem. Solids*, **31**, 1057 (1970).
- (38) (a) R. Eisenberg and J. A. Ibers, *J. Am. Chem. Soc.*, **87**, 3776 (1965); *Inorg. Chem.*, **5**, 411 (1966); (b) E. I. Stiefel, Z. Dori, and H. B. Gray, *J. Am. Chem. Soc.*, **89**, 3353 (1967); G. F. Brown and E. I. Stiefel, *Inorg. Chem.*, **12**, 2140 (1973); (c) M. J. Bennett, M. Cowie, J. L. Martin, and J. Takats, *J. Am. Chem. Soc.*, **75**, 7504 (1973).
- (39) R. Huisman and F. Jellinek, *J. Less-Common Met.*, **17**, 11 (1969).
- (40) B. F. Hoskins and B. P. Kelly, *Chem. Commun.*, 1517 (1968); 46 (1970).
- (41) See, however, E. I. Stiefel, *Inorg. Chem.*, **11**, 434 (1972).
- (42) This generalization may have exceptions. Various $\text{Ti}(\text{dik})_3^+$ are stereochemically nonrigid down to temperatures at least as low as -105°C : A. F. Lindmark, Ph.D. Thesis, Cornell University, Ithaca, 1975; R. C. Fay and A. F. Lindmark, *J. Am. Chem. Soc.*, **97**, 5928 (1975).
- (43) See M. J. Goldstein and R. Hoffmann, *J. Am. Chem. Soc.*, **93**, 6193 (1971).
- (44) Our analysis deals with the intermediate for a trigonal or Bailar twist (ref 8a, c), with the three ribbons spanning the rectangular edges of a trigonal prism. An analysis along these lines can also be carried out for the intermediate appropriate for a rhombic or Ray-Dutt twist (ref 8b, c) in which two of the ribbons are situated along triangular edges. The stereoisomerization of some $\text{Al}(\text{III})$ β diketones may proceed by the latter mechanism: M. Pickering, B. Jurado, and C. S. Springer, Jr., State University of New York at Stony Brook, private communication.
- (45) The Hückel molecular orbitals of many of these systems may be found in one of the standard compendia: C. A. Coulson and A. Streitwieser, Jr., "Dictionary of π -Electron Calculations", W. H. Freeman, San Francisco, Calif., 1965; E. Hellbronner and P. A. Straub, "Hückel Molecular Orbitals", Springer Verlag, Berlin, 1966. We checked the effect of heteroatom substitution by extended Hückel calculations with $X = \text{NH}$, $Y = \text{N}$.
- (46) C. G. Pierpont, H. H. Downs, and T. G. Rukavina, *J. Am. Chem. Soc.*, **96**, 5573 (1974); C. G. Pierpont and H. H. Downs, *ibid.*, **97**, 2123 (1975).
- (47) For a discussion of this overlap dependent conjugative destabilization see K. Müller, *Helv. Chim. Acta*, **53**, 1112 (1970); L. Salem, *J. Am. Chem. Soc.*, **90**, 543 (1968), *Proc. R. Soc. London, Ser. A*, **264**, 379 (1961).
- (48) M. Elian and R. Hoffmann, *Inorg. Chem.*, **14**, 1058 (1975).
- (49) M. R. Churchill, *Inorg. Chem.*, **6**, 185 (1967).
- (50) R. Ball and M. J. Bennett, *Inorg. Chem.*, **11**, 1806 (1972).
- (51) However, a recent structure of tetracarbonyl(2-methyl-3-prop-1-ynylmaleoyl)iron does show a slight distortion of this type, $\text{C}_5\text{-Fe-C}_6$ angle 166° : R. C. Pettersen, J. L. Cihonski, F. R. Young, III, and R. A. Levenson, *J. Chem. Soc., Chem. Commun.*, 370 (1975).
- (52) F. J. Hollander, R. Pedelty, and D. Coucouvanis, *J. Am. Chem. Soc.*, **96**, 4032 (1974).
- (53) J. L. Martin and J. Takats, *Inorg. Chem.*, **14**, 1358 (1975).
- (54) H. Abrahamson, J. R. Heiman, and L. H. Pignolet, *Inorg. Chem.*, **14**, 2070 (1975).
- (55) The GAUSSIAN 70 program (QCPE 236) can be obtained from the Quantum Chemistry Program Exchange, Chemistry Department, Indiana University, Bloomington Ind. 47401.
- (56) W. J. Hehre, R. F. Stewart, and J. A. Pople, *J. Chem. Phys.*, **51**, 2657 (1969); W. J. Hehre, R. Ditchfield, R. F. Stewart, and J. A. Pople, *ibid.*, **52**, 2769 (1970).
- (57) E. Clementi and J. W. Mehl, IBM System/360 IBMOL-Version 5 Program, IBM Research Laboratory, San Jose, Calif. 95114.
- (58) R. Hoffmann, *J. Chem. Phys.*, **39**, 1397 (1963); R. Hoffmann and W. N. Lipscomb, *ibid.*, **36**, 2179, 3489 (1962); **37**, 2872 (1962).